



Special Teams Playbook



Spring 2006



PAT Team

Cadence

- Color, #, Color, #, Set
- Holder flash hand to center when ready
- Center will snap when he is ready

Any Color (except Green, Blue) = Kick

- Everyone step inside with inside foot and one hinge step with outside foot
- Force all rushers outside

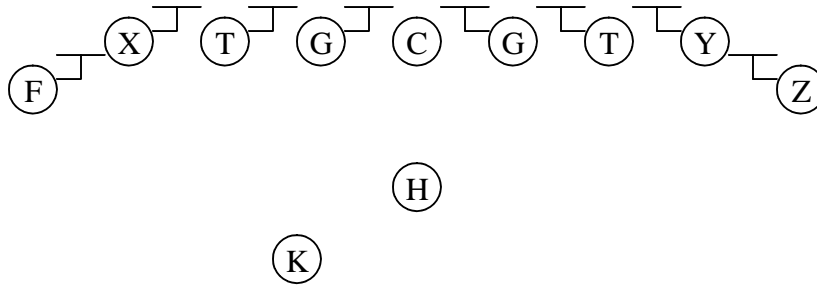

Green = Speed Option

- Everyone Block down to the right
- Leave Left End unblocked
- Holder Pitch on the Left End

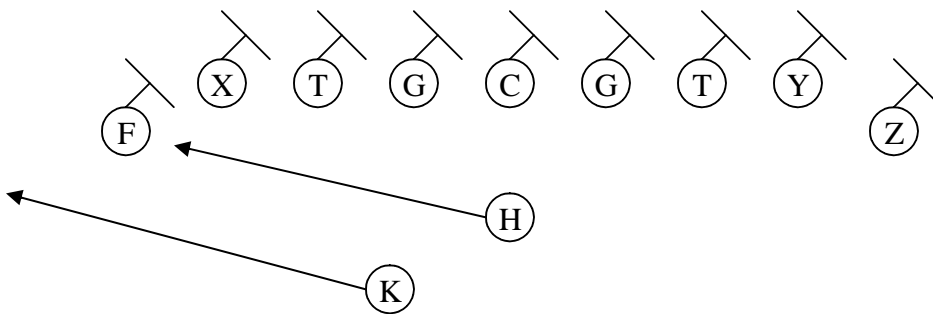

Blue = Flood Pass

- Z = Flat
- Y = Corner
- F = Drag
- Everyone else reach right
- Kicker step up to block backside rusher

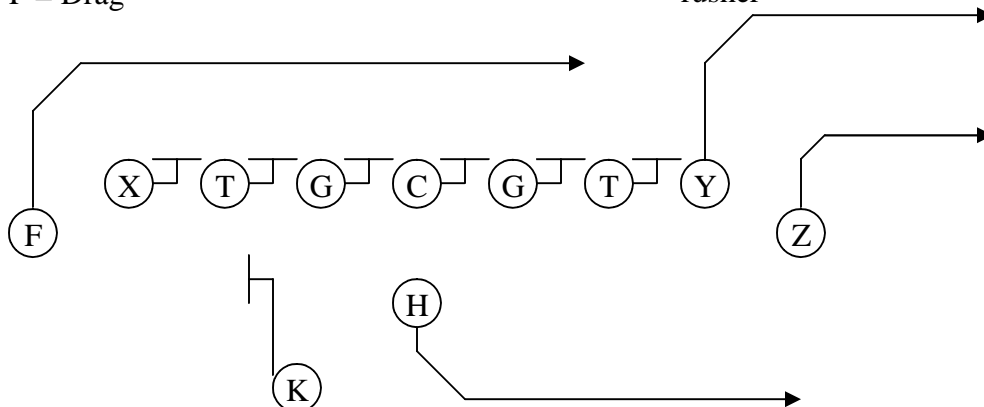

Punt Team

Cadence

- Protection, Protection, Set
- Punter flash hand to center when
- Center will snap when he is ready
- Rose/Linda = Right/Left
- Oscar, Roger, Leo = Fake Pass
- Tom, Left, Right = Fake Run

7 Linda/7 Rose = 7 Man Blitz (center = left/right)

- H = 1L, LT = 2L, LG = 3L, C = 4L/R, RG = 3R, RT = 2R, Y = 1R
- Fullback help leak to coverage
- X, Z = Runners

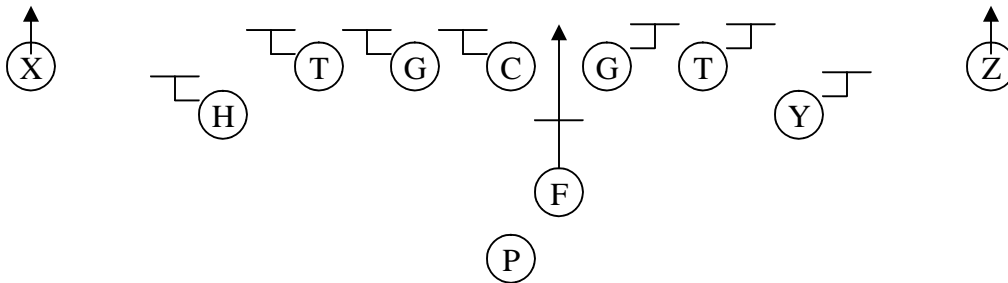

6 Linda/6 Rose = 6 Man Blitz (center = left/right)

- LT = 1L, LG = 2L, C = 3L/R, F = 3R/L, RG = 2R, RT = 1R
- X, H, Y, Z = Runners

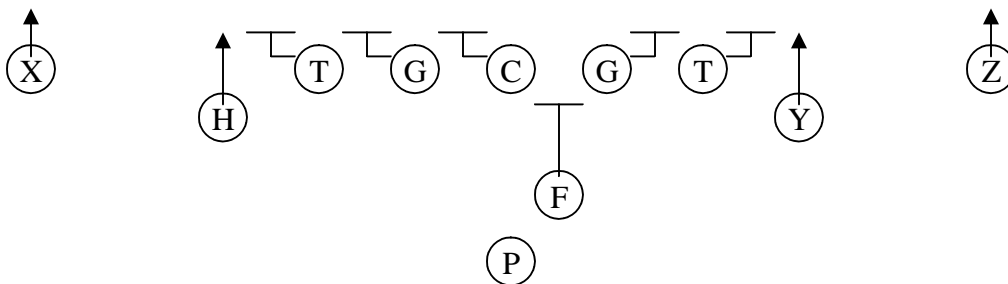

8 Linda/8 Rose = 8 Man Blitz (center = left/right)

- H = 1L, LT = 2L, LG = 3L, C = 4L/R, F = 4R/L, RG = 3R, RT = 4R
- X, Z = Runners

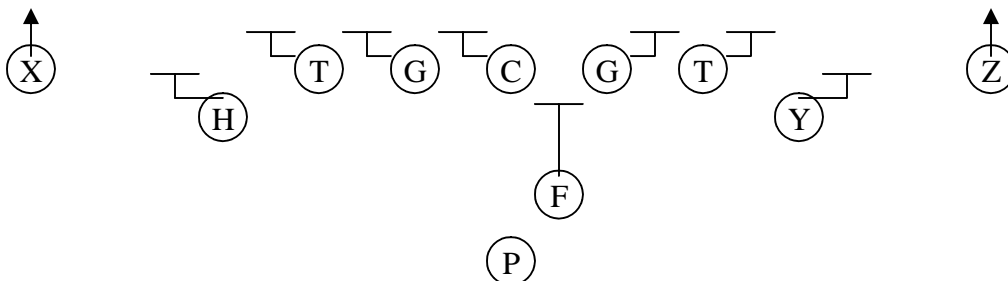

Right/# Left = Sweep Right/Left

- Punter Carries the ball
- X, Z = inside release to crack
- LG, C, RG = if uncovered backside shoulder, then pull
- Everyone Reach to Right/Left

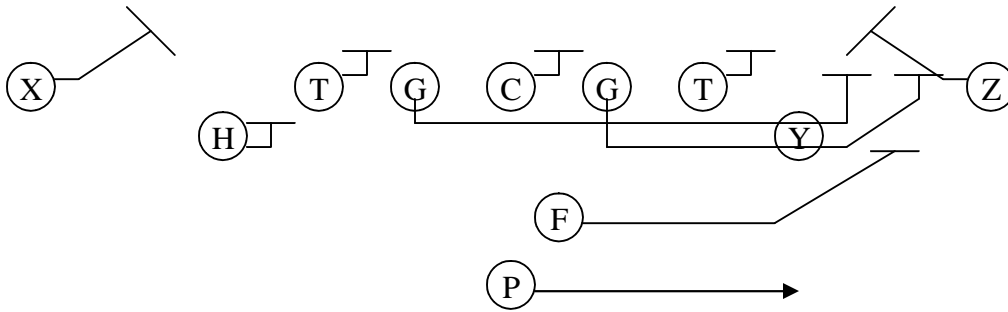

Oscar = Outs

- Same protection as 6 – Man: center goes to A-gap defender
- X, Z = Inside Release to slant
- H, Y = Inside Release to out
- P = Pocket Pass

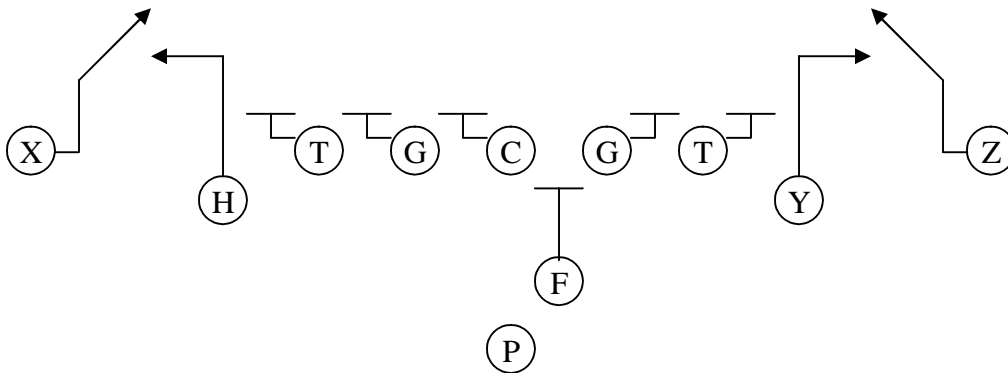

Roger/Leo = Rollout Right/Left

- All Lineman Reach to Right/Left
- F = Seal corner for Punter
- X, Z = Inside Release to Corner (PS), Post (BS)
- H, Y = Inside Release to Flat (PS), Climb (BS)

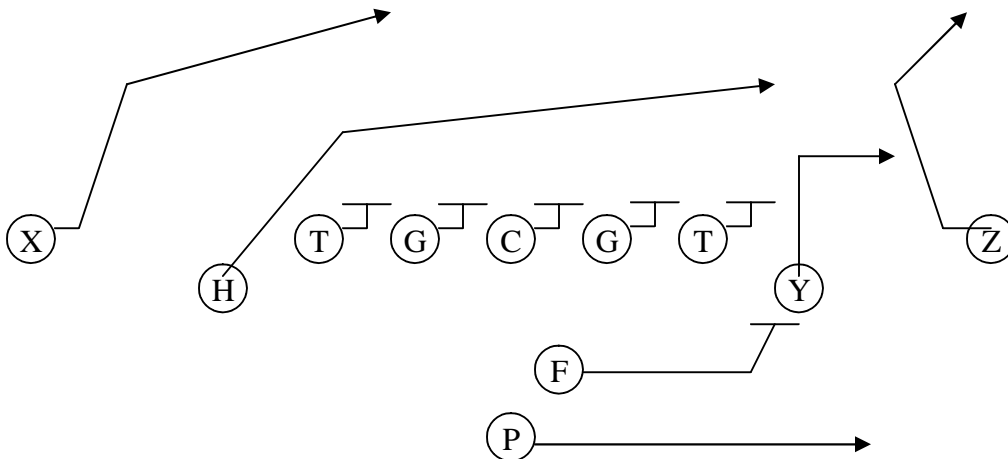

Kickoff Team

Deep Right/Middle/Left

- C = Contain
- R = Runner

- 1,2,3 = Lanes
- K = Safety

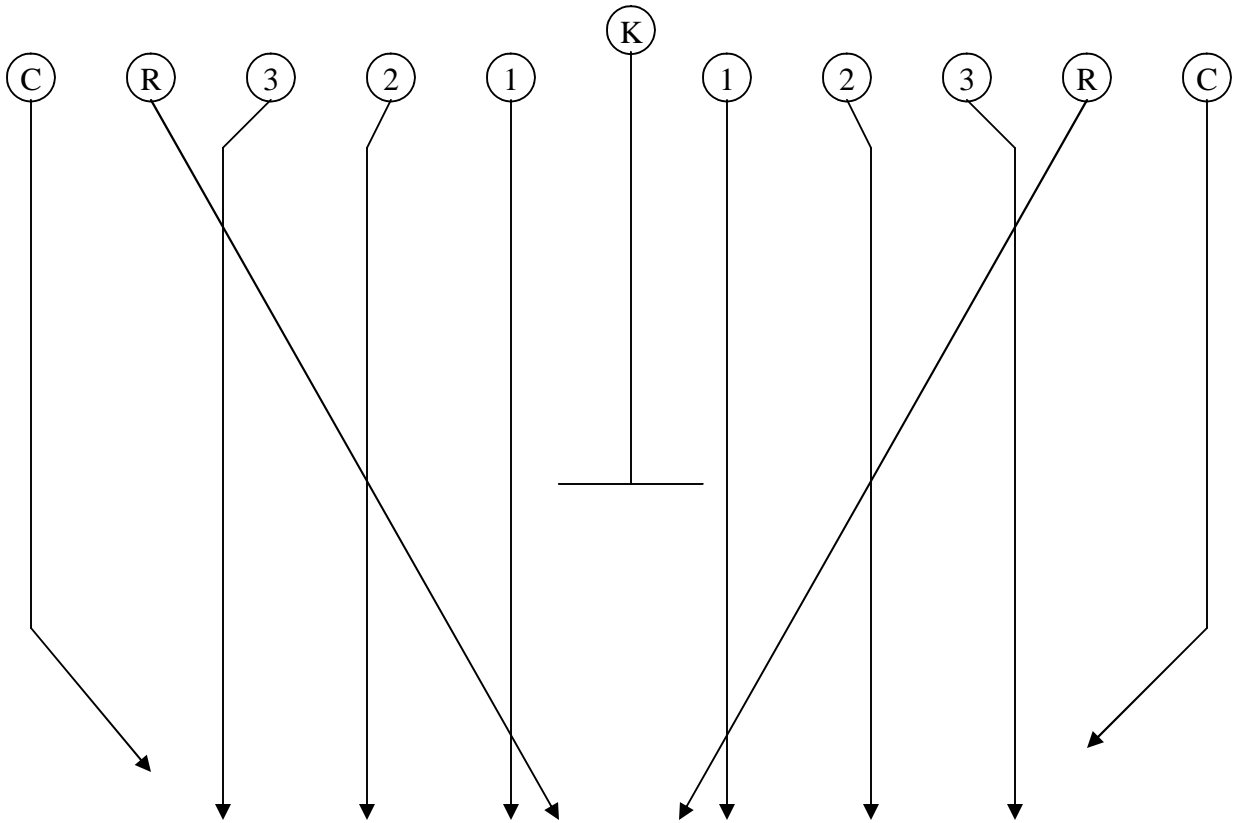

Onside

- C = Contain
- F = Free
- K = Safety
- S = Smashers
- L = Leapers

don't allow return away from onside
 go to ball, and watch for bounce
 kick and fall back in case of return
 take out front row of hands team
 leap up in air and recover onside kick

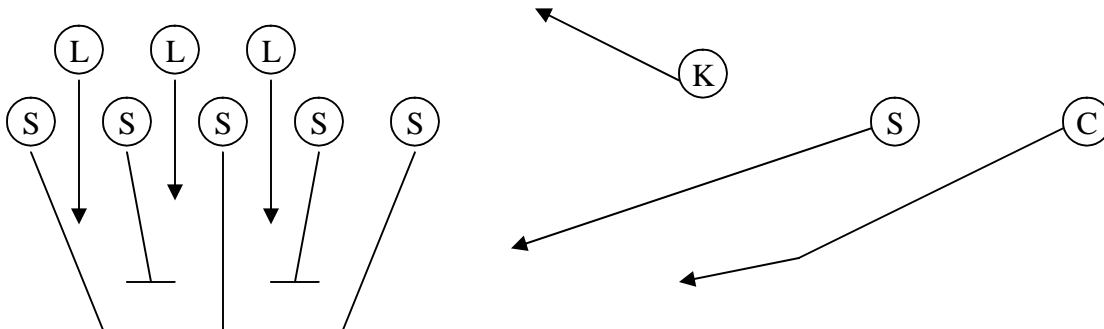

Field Goal Block Team

Alignment

- T, E, F, \$ = Head up on G, T, Y
- C = Outside Shoulder of W
- W, S = Stacked behind E
- M = head up on C

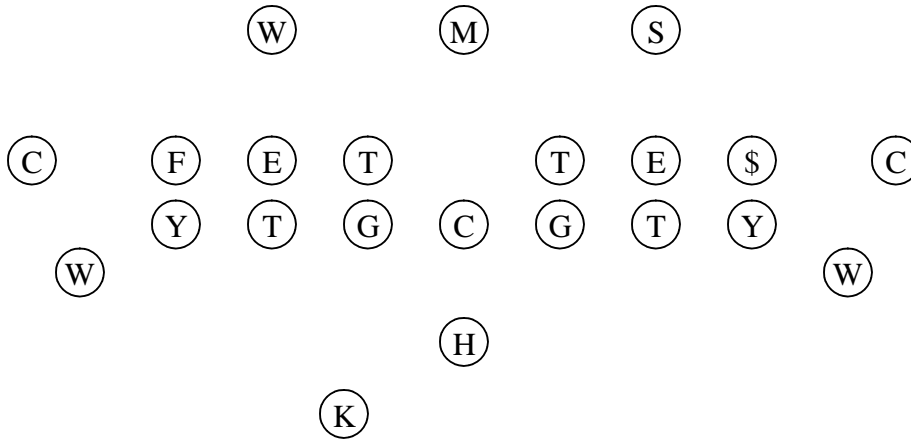

Cover

- T = Shoot A-gap
- E = Shoot B-gap
- C = Cover W
- F, \$ = Cover Y
- W, S = Cover H
- M = Cover K

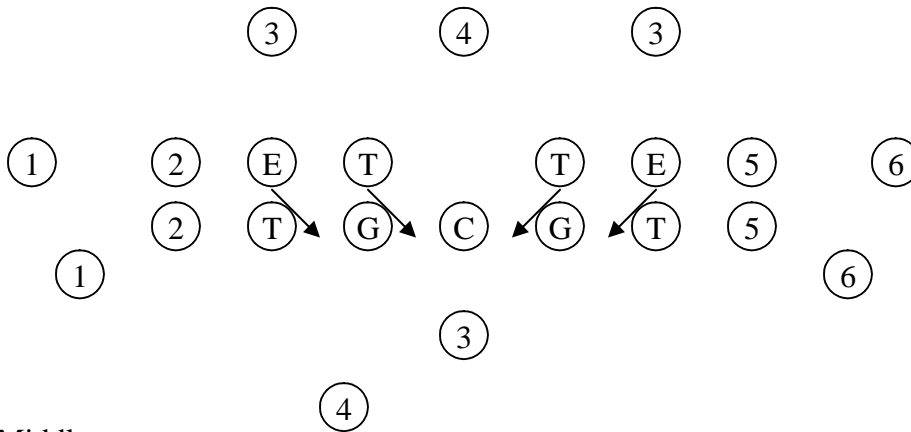

Block Middle

- T = Shoot A-gap
- W, S = Shoot B-gap
- E = Shoot C-gap
- M = Leap at LOS
- F, \$ = Cover Y
- C = Cover W

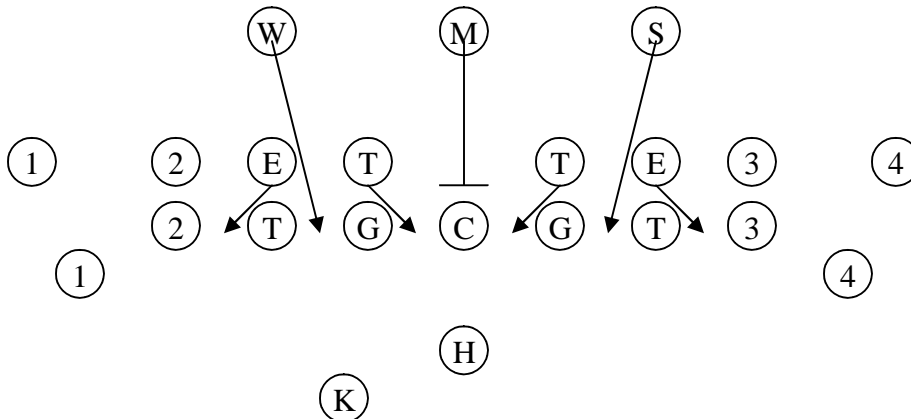

Block Right

- LE = Shoot B-gap
- LT = Shoot A-gap
- W, M = Shoot A-Gap
- RT = Shoot B-gap
- RE = Shoot C-gap
- F = Shoot D-gap
- RC = Outside Rush
- S = Cover H
- \$ = Cover Y
- LC = Cover W

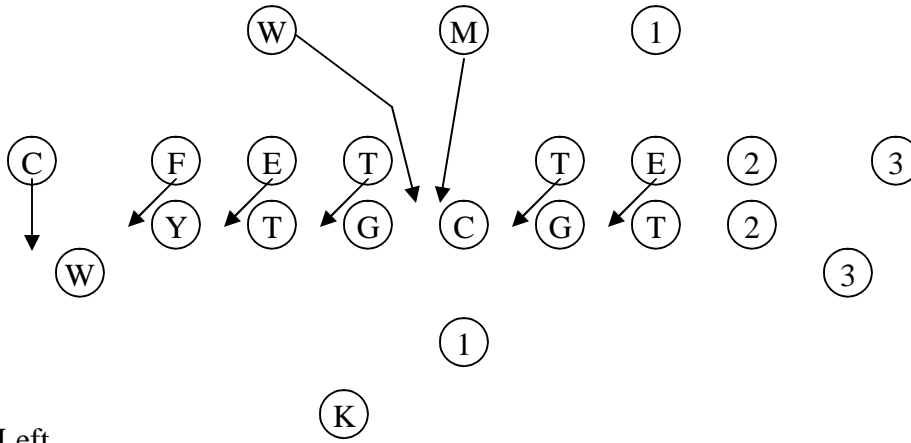

Block Left

- RE = Shoot B-gap
- RT = Shoot A-gap
- S, M = Shoot A-Gap
- LT = Shoot B-gap
- LE = Shoot C-gap
- \$ = Shoot D-gap
- LC = Outside Rush
- W = Cover H
- F = Cover Y
- RC = Cover W

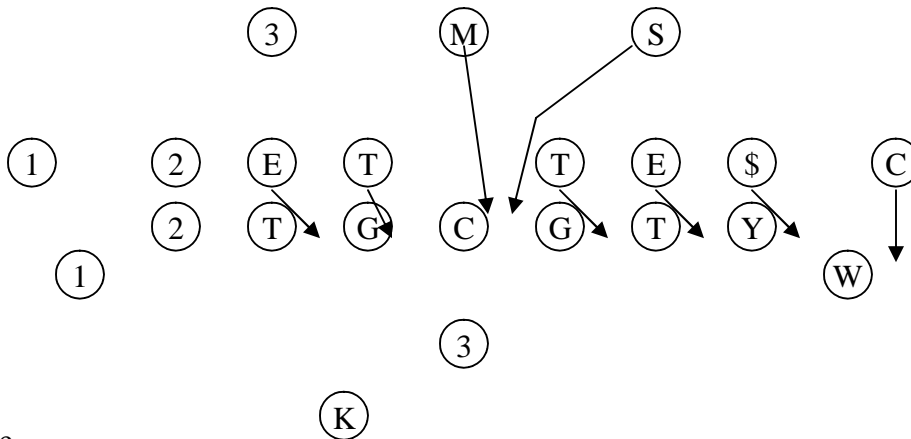

Gamble

- Everyone Shoot inside Gap
- W, M, S = Leap at LOS

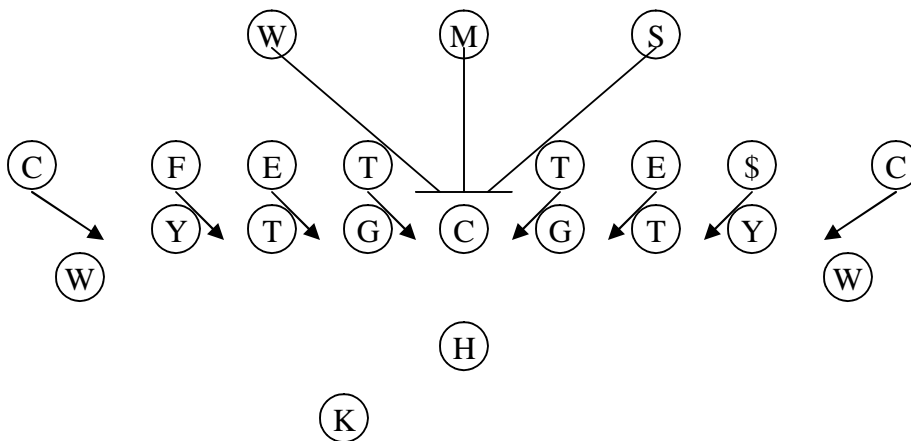

Punt Return Team

Alignment

- T = 2i
- E = 5
- W, S = 7
- M = Over center
- C = Inside shade of B
- U = 20 yards
- R = 35 yards

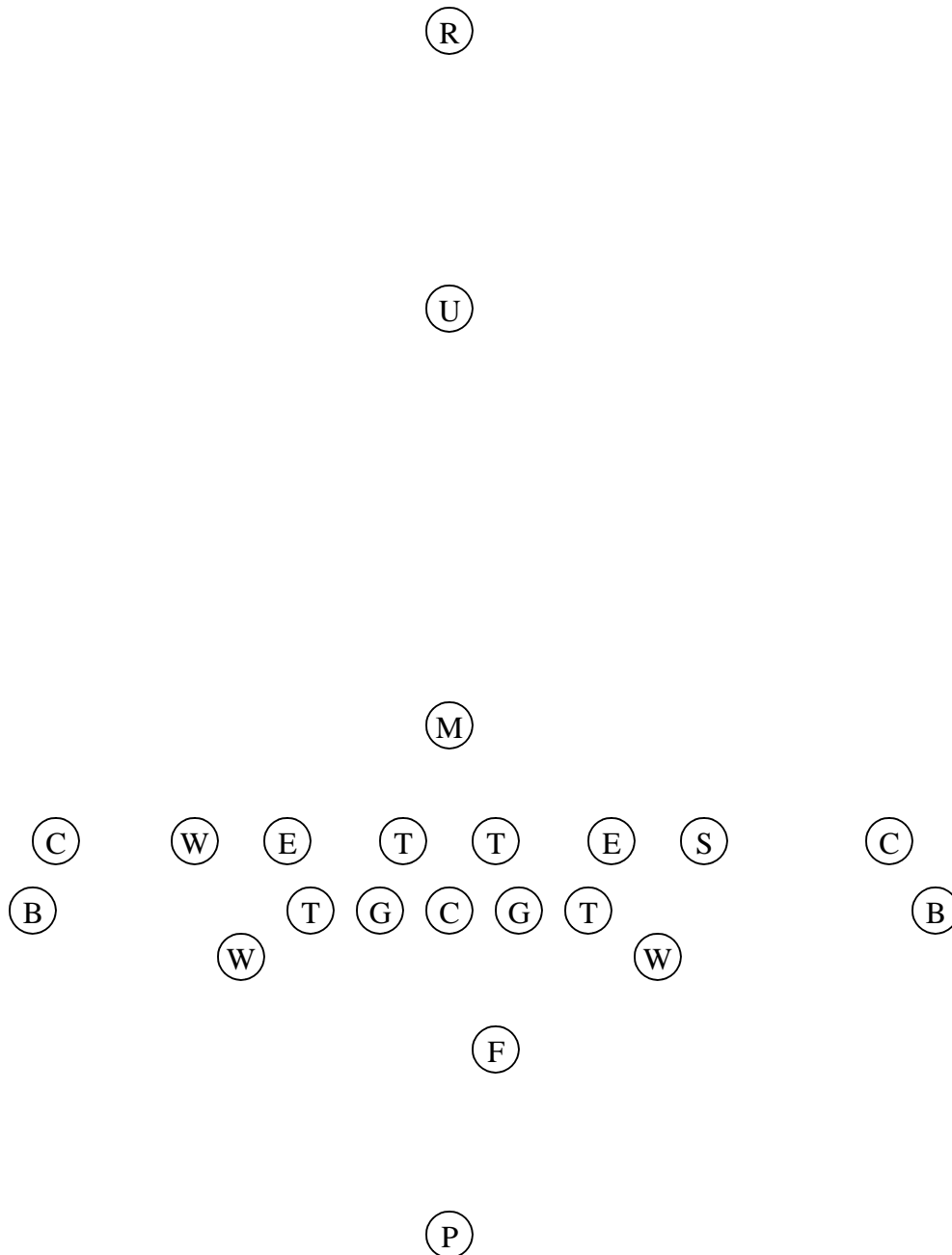

Return Middle

- T, E, W, S = Engage G, T, W
 - Force outside hash
- M = Wait for C to release
 - Engage C & force to hash
- C = Bump B and force past R
 - Force outside hash
- U = Catch punt if short
 - Lead up middle of field
 - Engage first man through

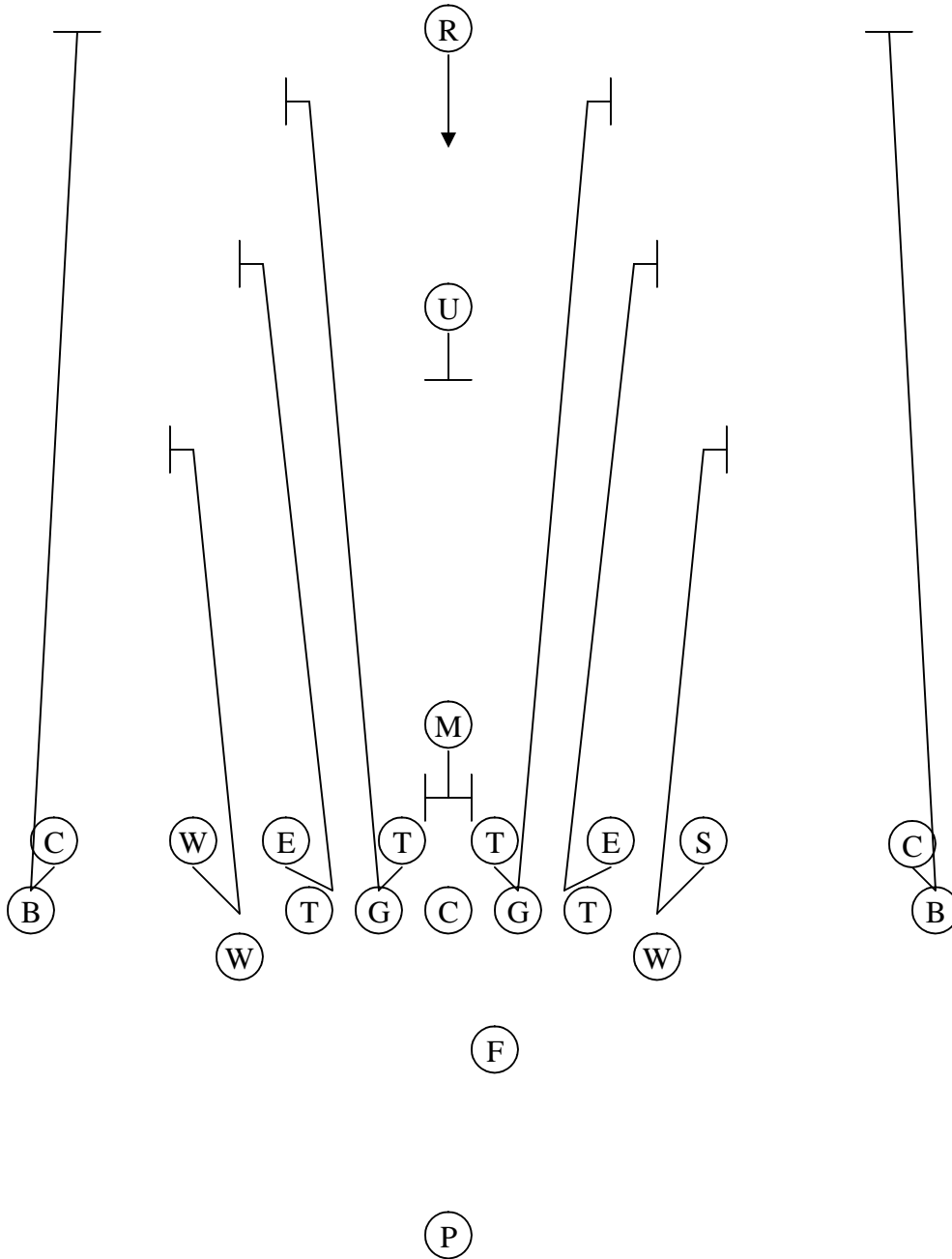

Return Left

- W, RE = Release at snap
 - Get to opposite hash
 - Peel to middle
- T, LE, S = Engage G, T, W
 - Force to right
- M = Wait for C to release
 - Engage C & force to right
- C = Bump B and force past R
 - Engage C & force to right
- U = Catch punt if short
 - Lead to left

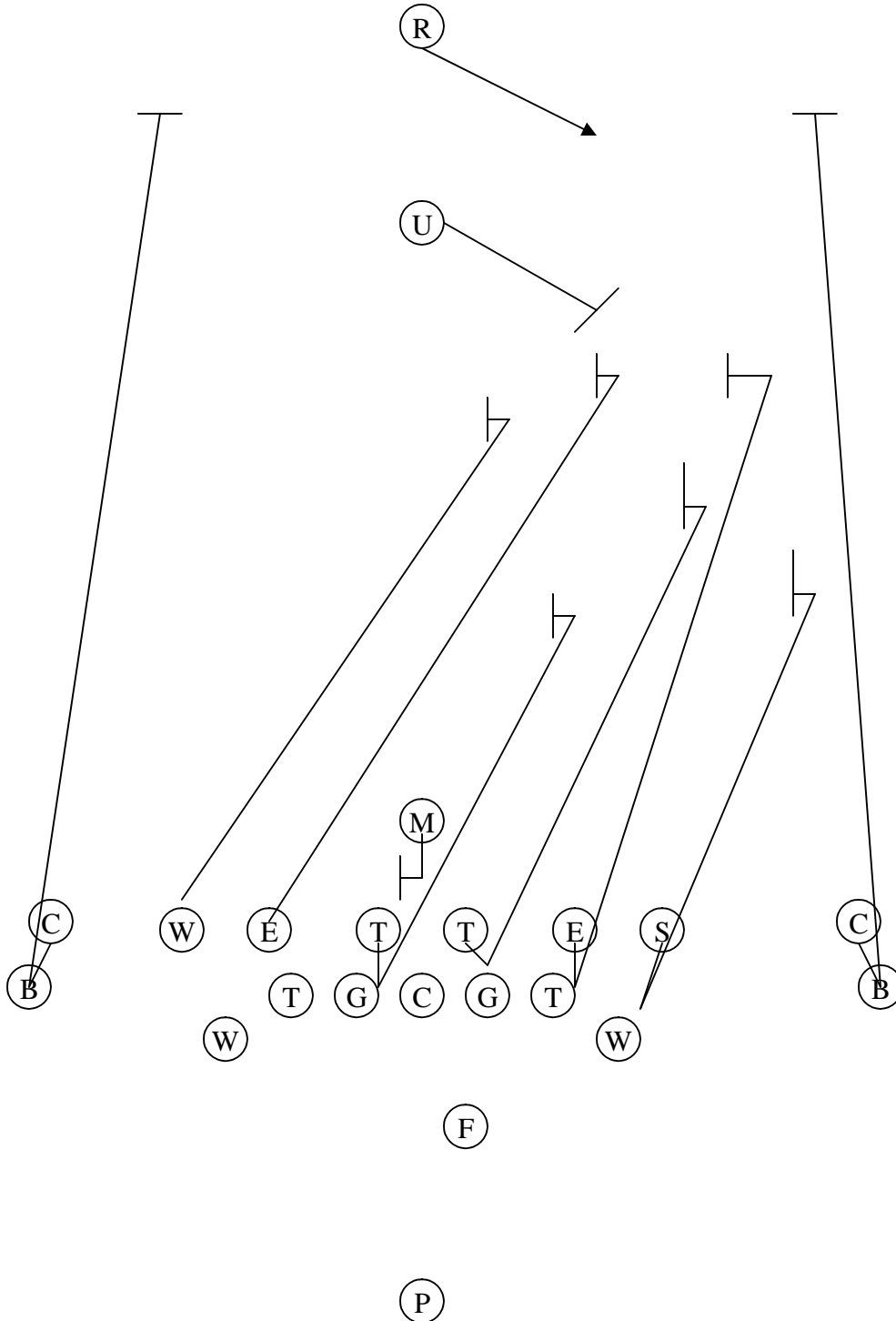

Return Right

- S, LE = Release at snap
 - Get to opposite hash
 - Peel to middle
- T, RE, W = Engage G, T, W
 - Force to left
- M = Wait for C to release
 - Engage C & force to left
- C = Bump B and force past R
 - Engage C & force to left
- U = Catch punt if short
 - Lead to right

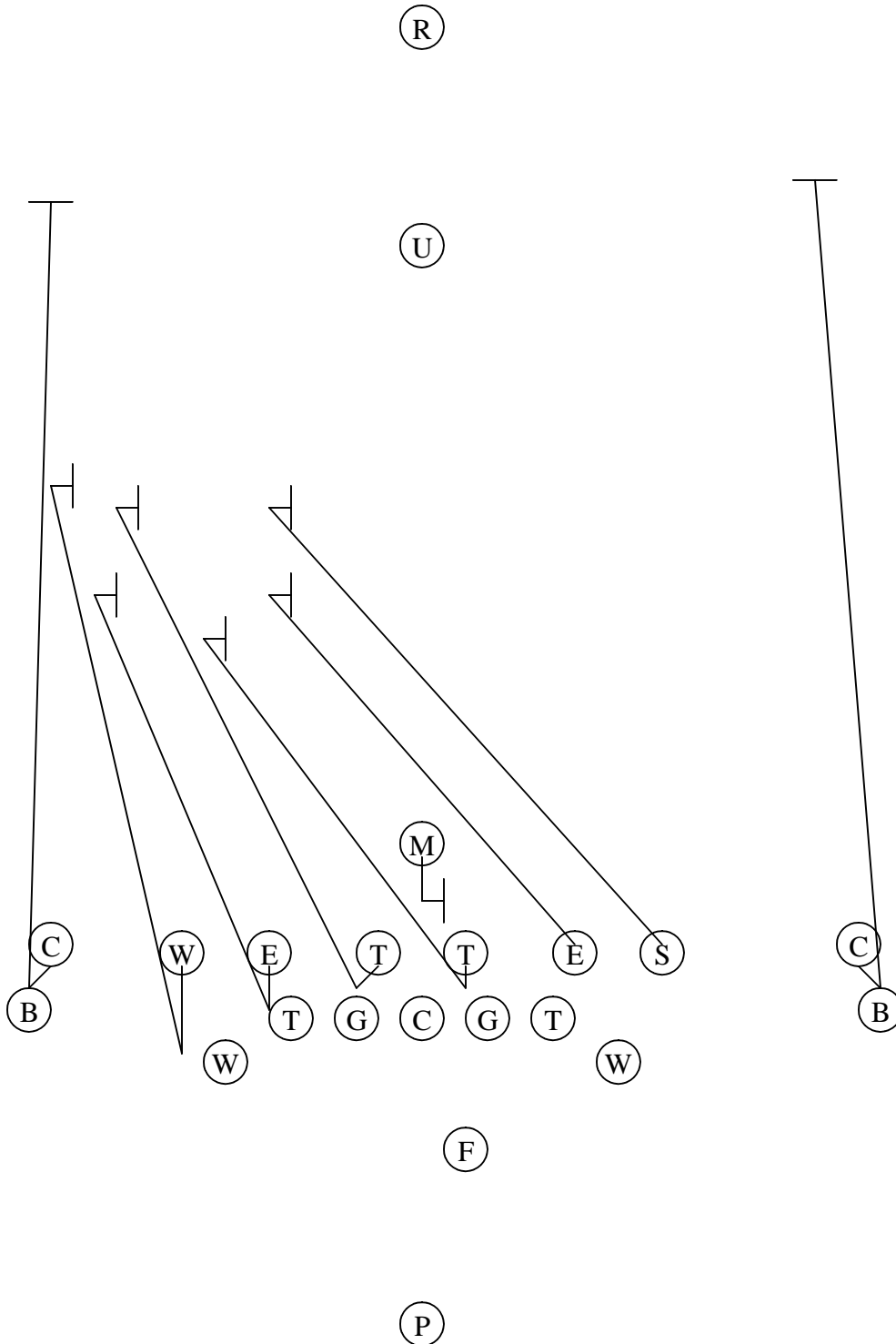

Block Middle

- T = Shoot A-gap
- M, U = Shoot B-gap
- C = Bump B and force past R
- W, S, E = Engage W, T
 - Force outside hash
- R = Catch & return middle

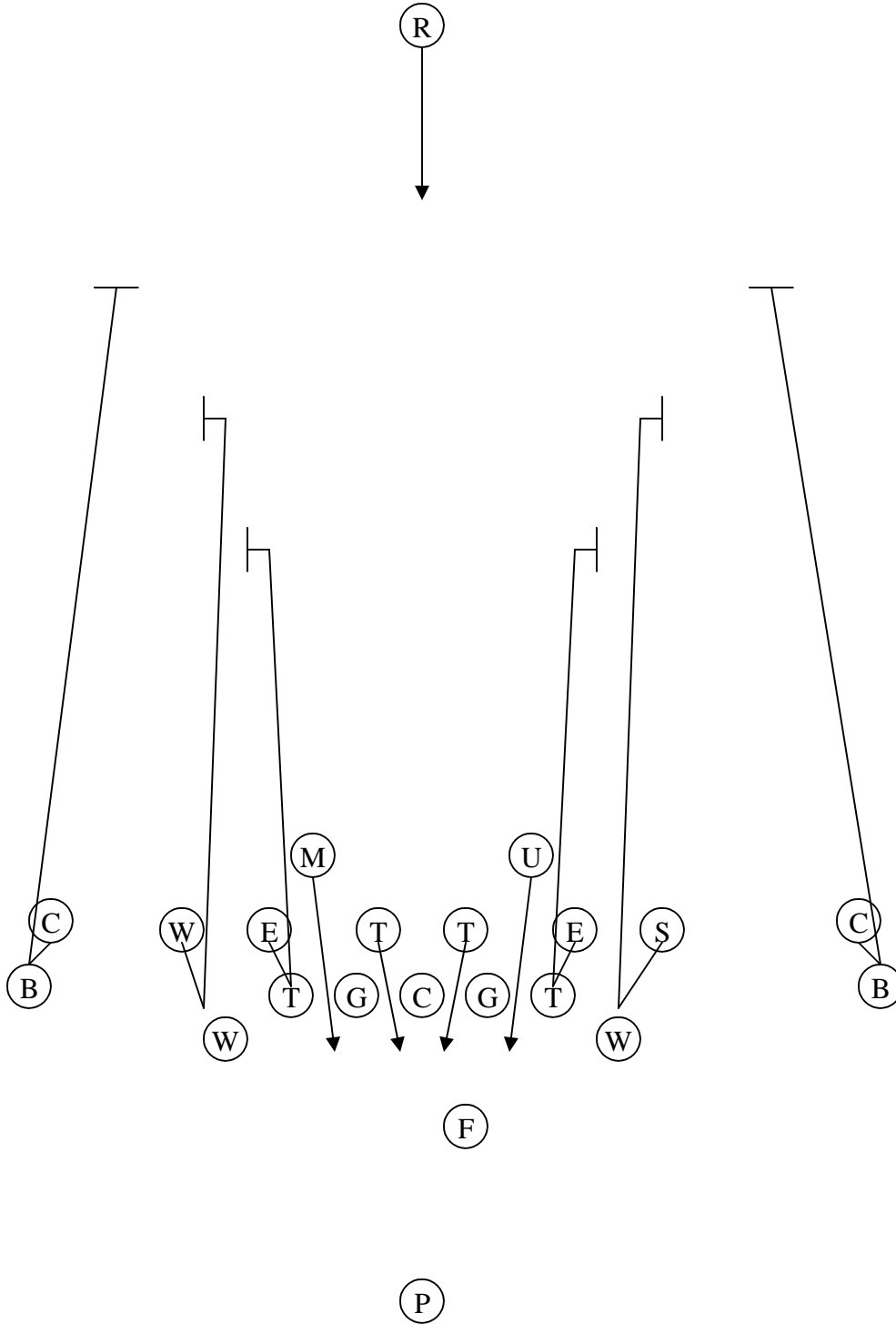

Block Left

- LT = Shoot A-gap
- M = Shoot B-gap
- LE, U = Shoot C-gap
- S = Shoot D-gap
- C = Bump B and force past R
- RT, RE, W = Engage G, T, W
 - Force left
- R = Catch & return right

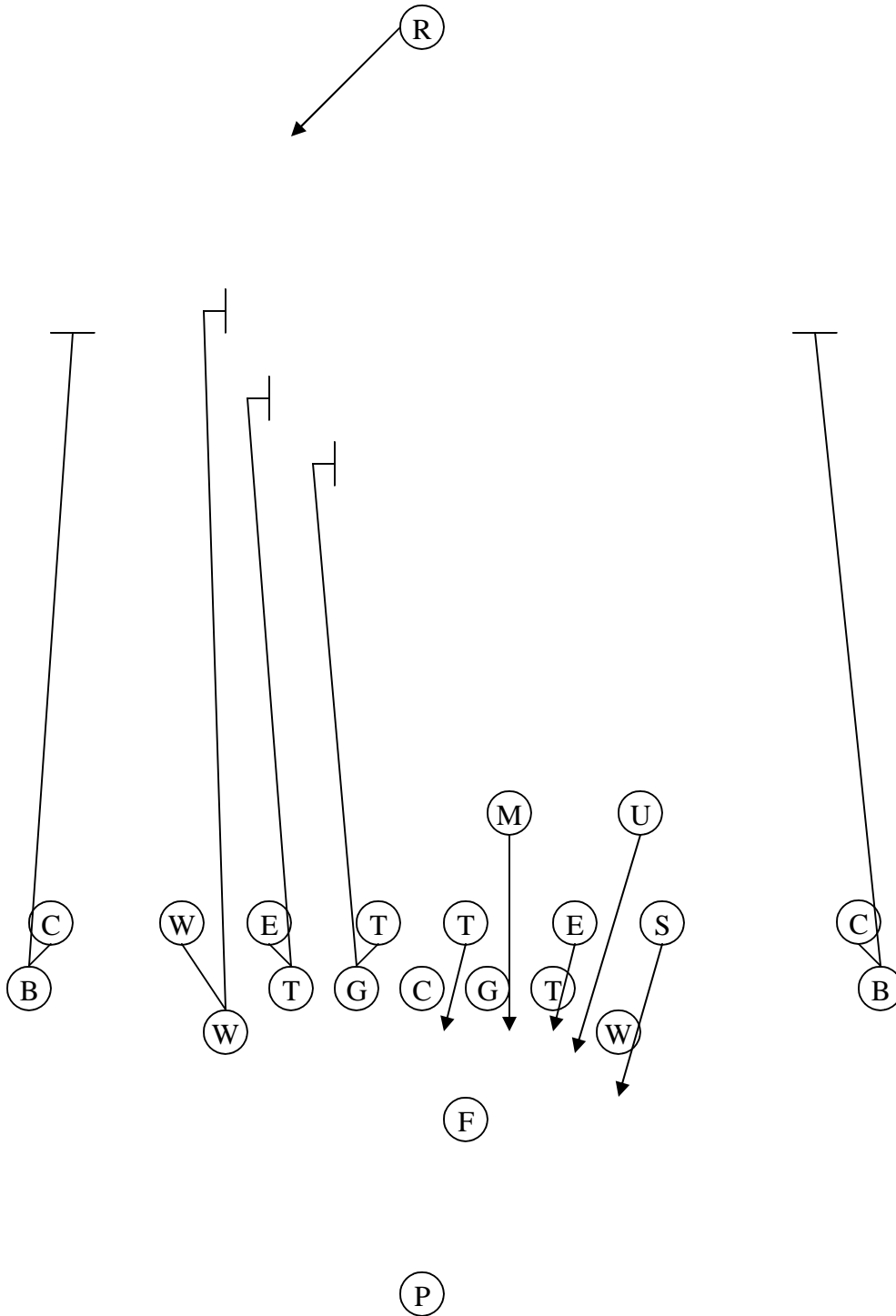

Block Right

- RT = Shoot A-gap
- M = Shoot B-gap
- RE, U = Shoot C-gap
- W = Shoot D-gap
- C = Bump B and force past R
- LT, LE, S = Engage G, T, W
 - Force right
- R = Catch & return left

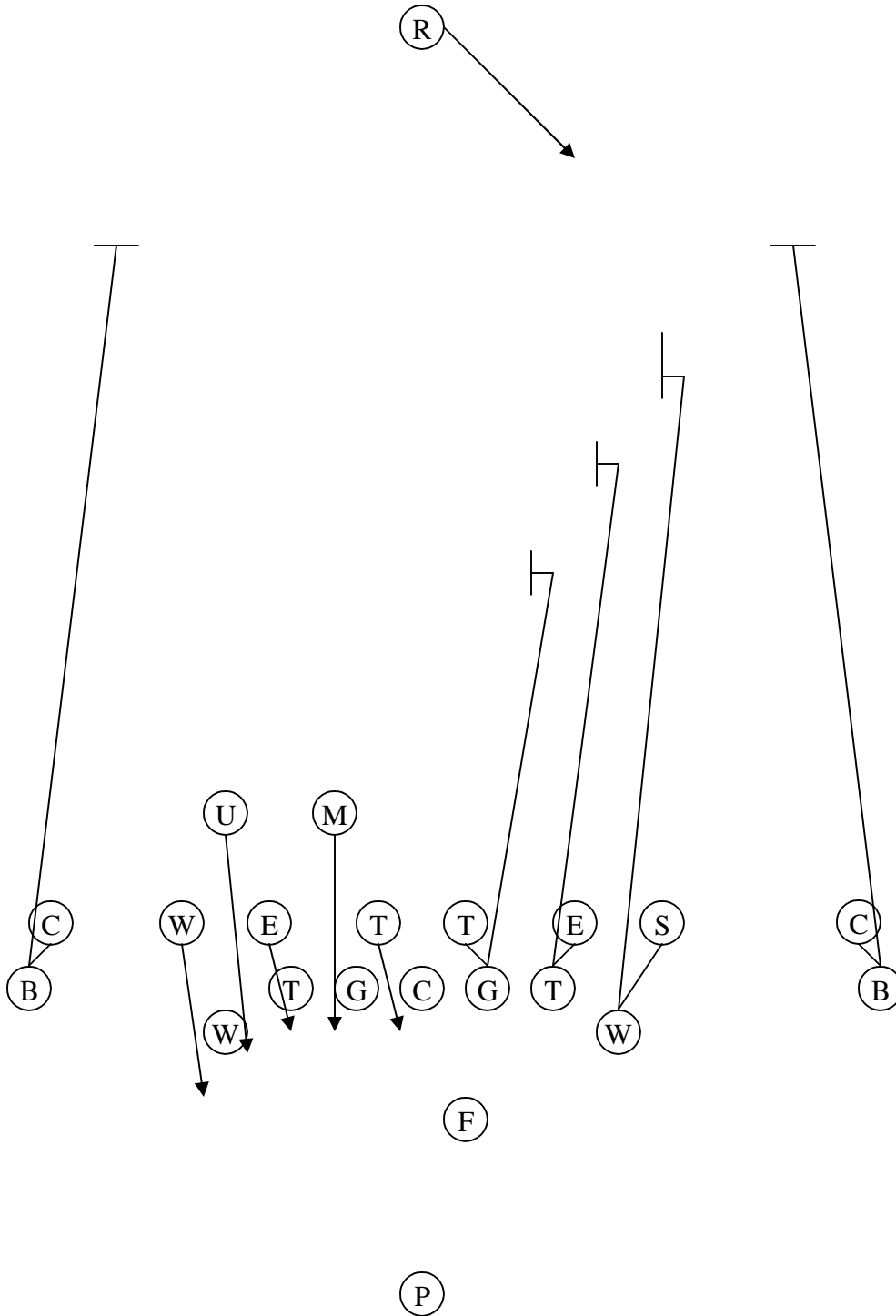

Gamble

- M, U = Shoot A-gap
- T = Shoot B-gap
- E = Shoot C-gap
- W, S = Shoot D-gap
- C = Bump B and force past R
- R = Catch and Return

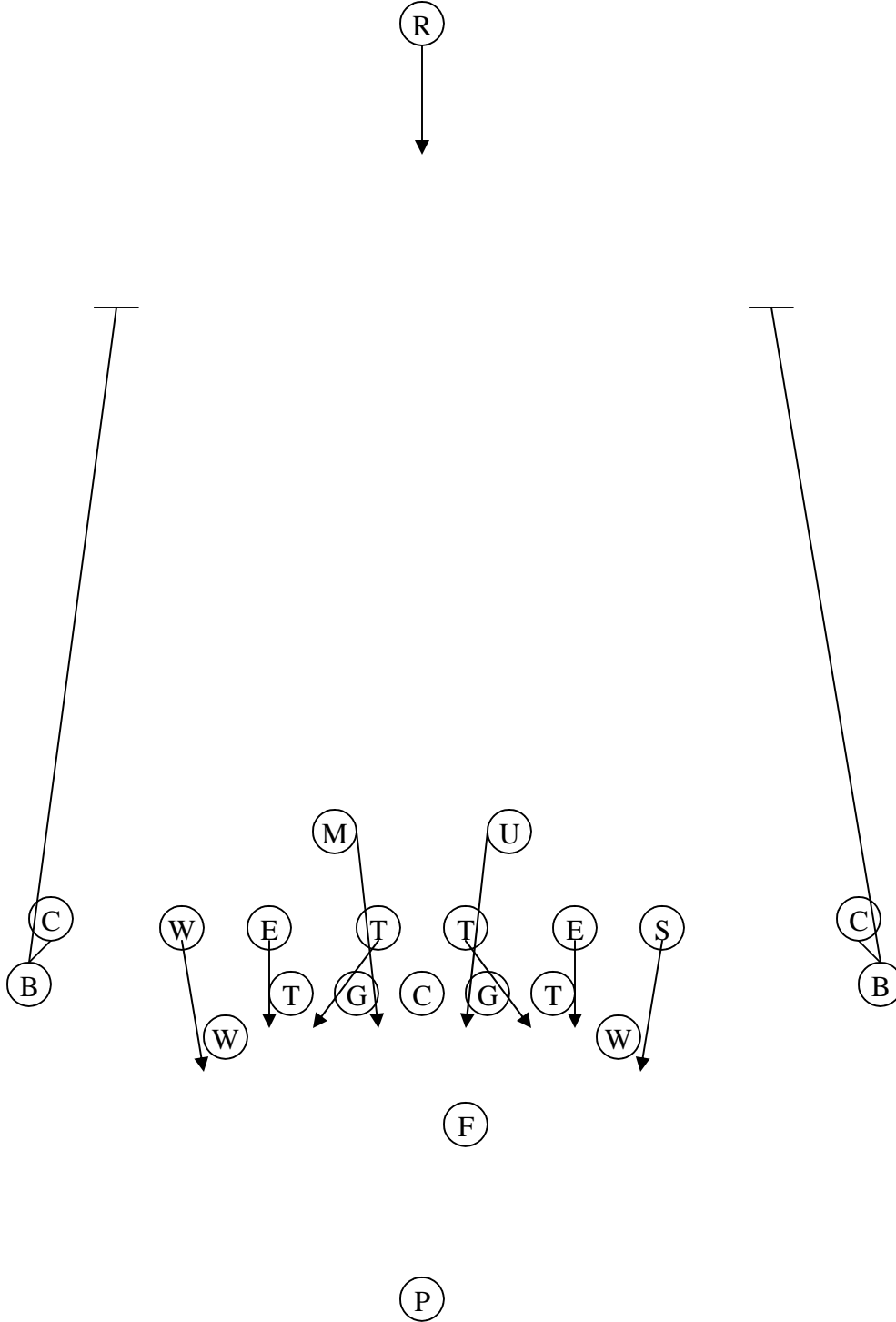

Kickoff Return Team

Alignment

- Count the kickoff team from left to right
 - Exclude K
- T, G, C = 10 yards from ball
 - C = Middle of field
 - G = Hash
 - T = Inside numbers
- W = 20 yards from ball
 - On #'s
- F = 25 yards from ball
 - Between hash and #'s
- R = 5 yard line
 - Hash

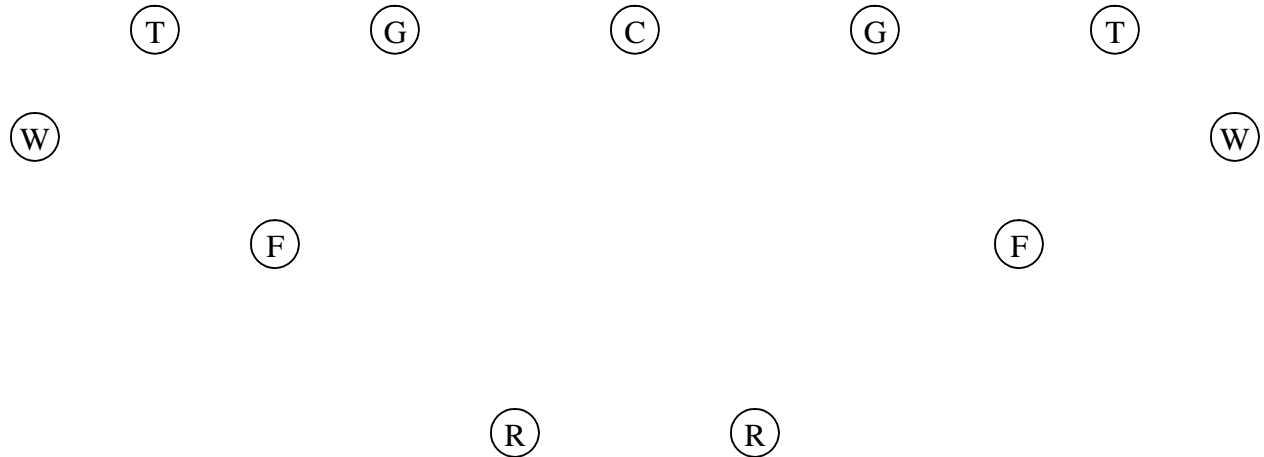

Return Middle

- W, T, G, C = Middle Wedge
- F = Block Runners
- R = Catch if ball comes to you
 - Lead up wedge if ball away

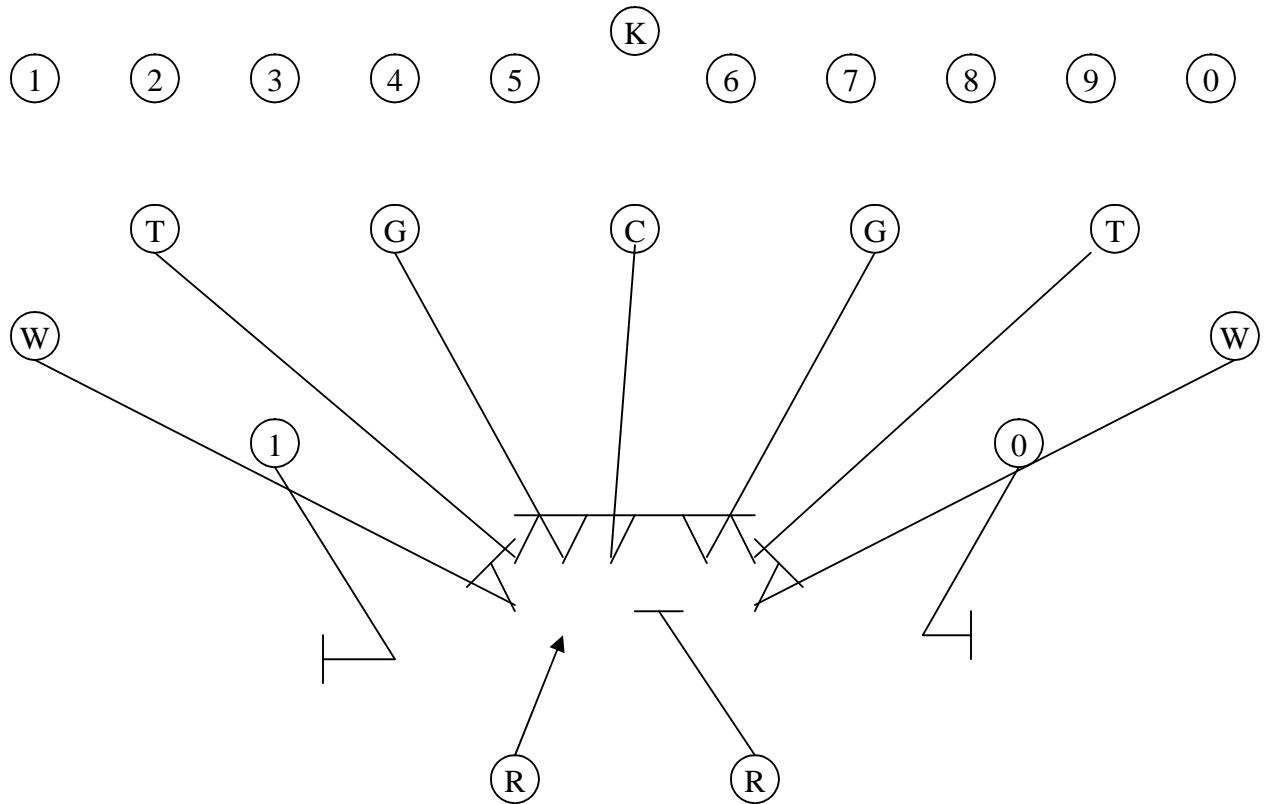

Return Right

- RW, RT, RG, C = Wedge Right
 - Pick up 6, 7, 8
- LG = 5
- LT = 4

- LW = 3
- F = Block Runners
- R = Catch if ball comes to you
 - 9 if ball goes away

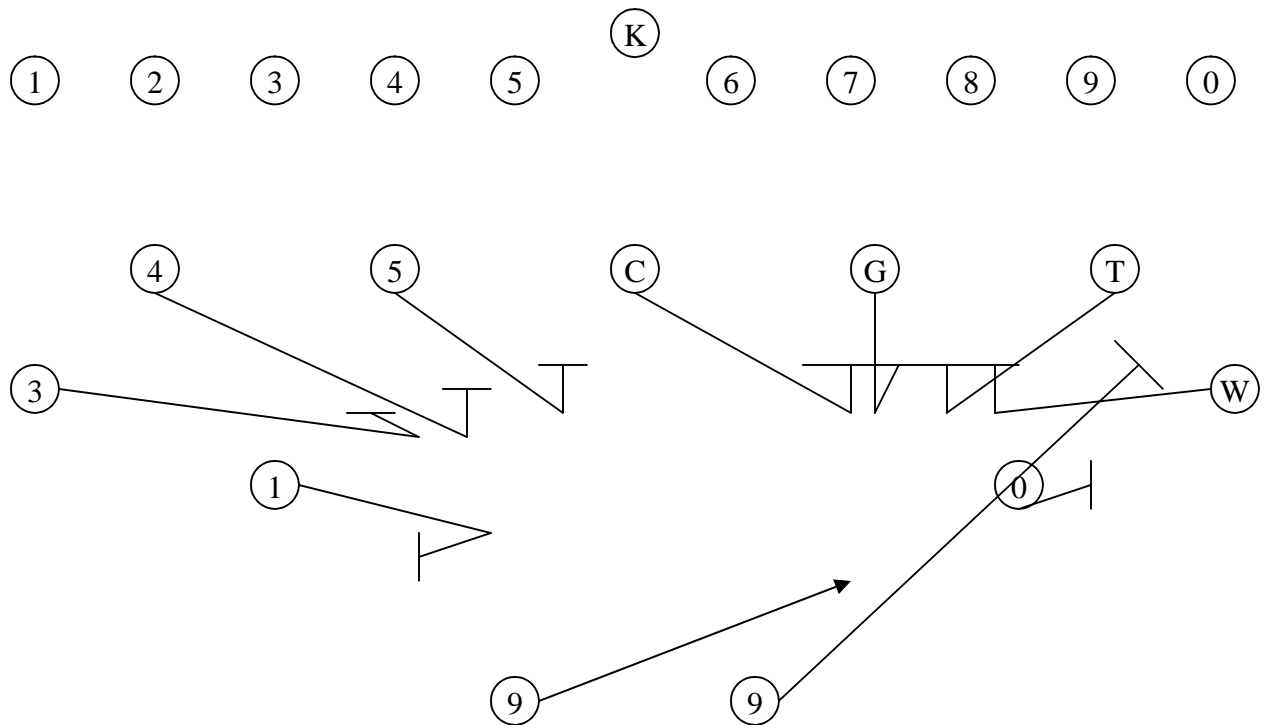

Return Left

- LW, LT, LG, C = Wedge Left
 - Pick up 3, 4, 5
- RG = 6
- RT = 7

- RW = 8
- F = Block Runners
- R = Catch if ball comes to you
 - 2 if ball goes away

